

Pedestrian Gates

MPT 132 / 33 / 30

The MPT series of full height security turnstiles are designed to control pedestrians entering or exiting restricted areas where perimeter control is required. This turnstile can be used for bidirectional pedestrian access control applications.

The turnstile has been designed as a modular system and can easily be assembled on site by hand and without the need of heavy lifting devices.

Additional space has also been made available for the installation of access control equipment. The turnstile is designed to be installed directly to concrete surfaces.

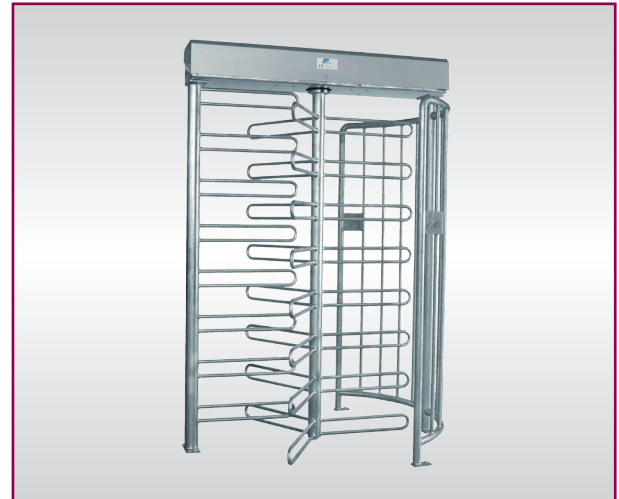

Housing and quality

The turnstile consists of an outer 'U' bar section, an outer vertical bar section, a central rotating column and a folded sheet metal enclosure in which the control and drive mechanism is installed. As standard, all sections are fully "hot dip" galvanised after fabrication and can also be powder-coated in RAL 7042 (grey) upon request. Optional RAL colours and either 304 or 316 grade stainless steel construction are also available upon request.

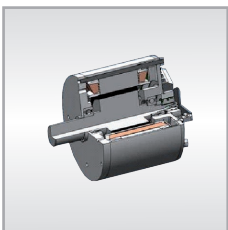

Models and technology

There are three different models of MPT turnstiles: . The MPT 132 (motor-driven) is based on the MHTM™ technology that offers very smooth operation. The MPT 33 (electromechanical) is rotated manually by the user. The locking mechanism contains a cam plate and two locking solenoids. The MPT 30 (mechanical) is the most easiest model for e.g. exiting of recreational parks, public baths and smimilar venues



Comprehensive accessories

The MPT series of full height turnstiles offers a comprehensive range of accessories like additional swing doors for e.g. cyclists, roofs, overhead lighting within the turnstile, etc. A specifically designed foundation frame provides easy installation on paved undergrounds. Customer-specific access control devices can be easily installed using the optional housing which is mounted at the outer cage section.



Safety

The drive unit of the MPT 132 offers very low impact forces as well as impact detection. By default, the passage is free in case of a power failure.

Technical data	MPT 132	MPT 33	MPT 30
Technology	motor-driven (MHTM™)	electromechanical	mechanical
Voltage	110 - 240 V AC	110 - 240 V AC	-
Frequency	50 - 60 Hz	50 - 60 Hz	-
Amperage nom. / max.	0.3 / 1.0 A	0.32 / 0.44 A	-
Duty cycle	100 %	100 %	-
Protection class	IP 43	IP 43	IP 43
Dimensions (WxLxH)	1288 x 1500 x 2235 mm	1288 x 1500 x 2235 mm	1288 x 1500 x 2235 mm
Weight	325 kg	320 kg	320 kg
Ambient temperature	-25 to +55 °C	-25 to +55 °C	-25 to +55 °C

Dimensional drawing

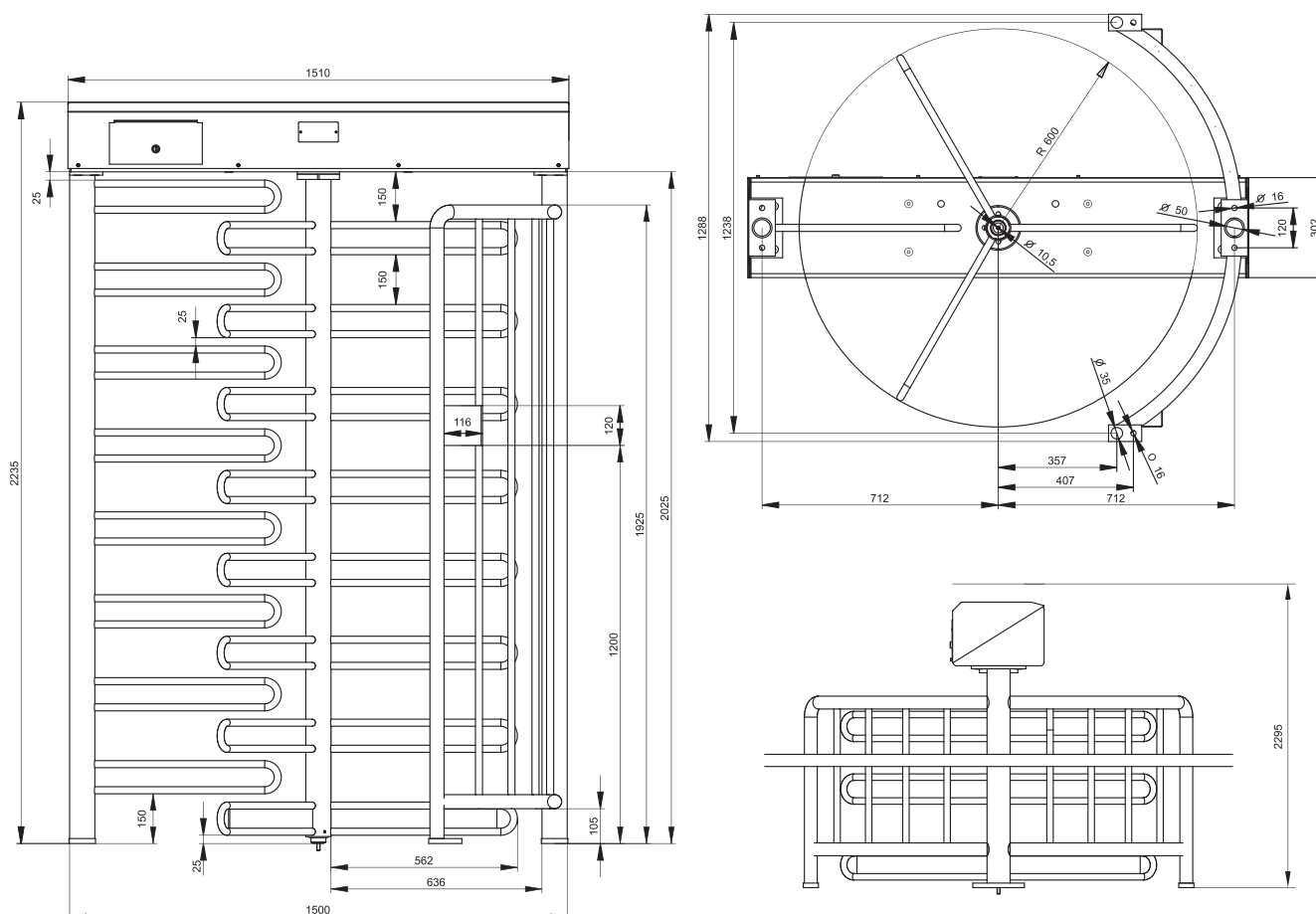

Pedestrian Gates

MPT 152 / 53

The MPT152/53 series of full height turnstiles have been specifically developed to control simultaneous bi-directional pedestrian control of two independent turnstiles where limited space is available.

The turnstile has been designed as a modular system and can easily be assembled on site by hand and without the need of heavy lifting devices.

Additional space has also been made available for the installation of access control equipment. The turnstile is designed to be installed directly to concrete surfaces.



Turn-
stile
Swing
Wing /
Flap
Tripod



Housing and quality

Each turnstile consists of an outer cage section and a centre column incorporating a 3 x 120° offset 'U' bar configuration. The Controller and the drive are mounted on top of the cage and within a sheet metal enclosure. By default, all sections are fully "hot dip" galvanised and can be powder-coated in RAL 7042 (grey) upon request. Optional RAL colours and either 304 or 316 grade stainless steel construction are also available upon request.

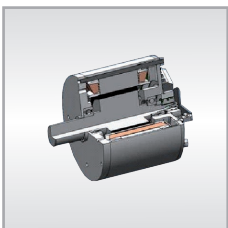

Models and technology

There are two models of MPT double turnstiles: . The MPT 152 (motor-driven) is based on the MHTM™ technology that offers almost silent operation, low dynamic forces, impact detection, and very quick opening and closing times. The MPT 53 (electromechanical) is rotated manually by the user. The locking mechanism contains a cam plate and two locking solenoids.



Comprehensive accessories

The MPT series of full height turnstiles offers a comprehensive range of accessories like additional swing doors for e.g. cyclists, roofs, overhead lighting within the turnstile, etc. A specifically designed foundation frame provides easy installation on paved undergrounds. Customer-specific access control devices can be easily installed using the optional housing which is mounted at the outer cage section.



Safety

The drive unit of the MPT 152 offers very low dynamic forces as well as impact detection. By default, the passage is free in case of a power failure. An optional locking device to stop entry in one or both directions is available upon request.

Technical data	MPT 152	MPT 53
Technology	motor-driven (MHTM™)	electromechanical
Voltage	110 - 240 V AC	110 - 240 V AC
Frequency	50 - 60 Hz	50 - 60 Hz
Amperage nom. / max.	0.3 / 1.0 A	0.32 / 0.44 A
Duty cycle	100 %	100 %
Protection class	IP 43	IP 43
Dimensions (WxLxH)	2210 x 1313 x 2235 mm	2210 x 1313 x 2235 mm
Weight (per turnstile)	315 kg	310 kg
Operating temperature	-25 to +55 °C	-25 to +55 °C

Dimensional drawing

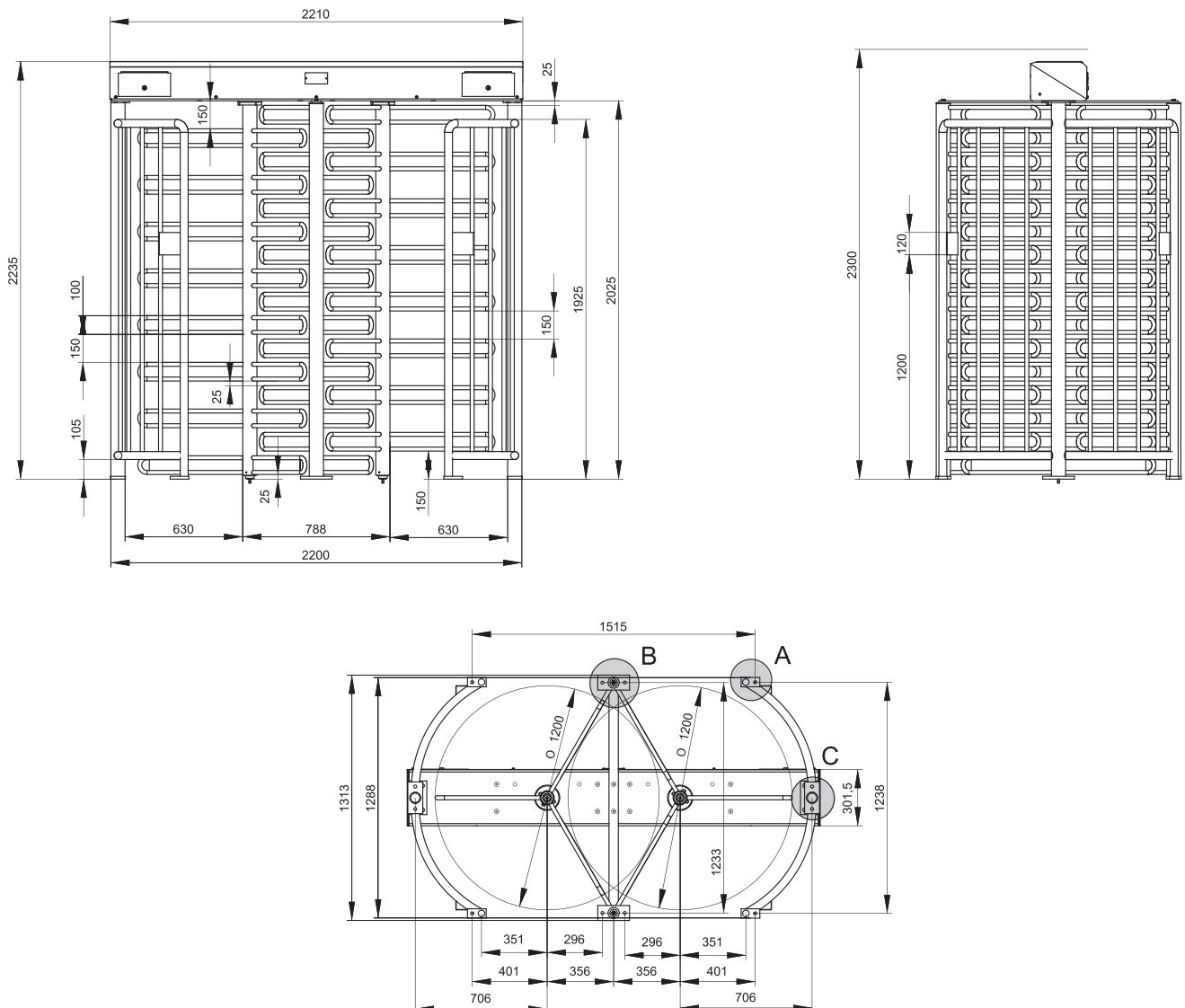

Pedestrian Gates

MPG 162 / 172

MPG swing doors are designed to grant access to secured areas to user groups like bicyclists or wheelchair user. There are two models available: a stand-alone solution (MPG 172) and a model for combination with turnstiles MPT (MPG 162).

MPG swing doors consist of an upper housing (including the control units and drive unit), a swing door and blocking devices.

The door movement of both types is 2 x 90°. Activation of the door is normally realized by means of access control units. Optionally, the door may be equipped with one-sided or both-sided induction loops for bicycles.



Housing and quality

Thanks to the modular design, the delivery of the swing door is done in pre-assembled components. MPG swing doors are available with different surfaces, e.g. hot-dipped, powder-coated or stainless steel (door).

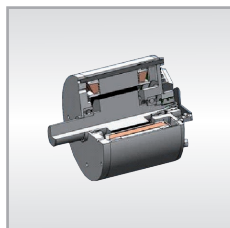

Motor and control unit

The drive unit includes the MHTM™ drive technology. This technology offers numerous advantages like durability, no need for maintenance, noiseless operation, low dynamic forces, obstacle detection and harmonic opening / closing movements. In normal position, the motor is being supplied with marginal current. The resulting heat prevents condensation and allows the usage in almost every environment.



Safety

The drive unit of the MPG swing door offers very low dynamic forces as well as impact detection. By default, the passage is free in case of a power failure. An optional locking device to stop entry in one or both directions is available upon request.



Comprehensive accessories

The MPG series offers a wide range of accessories like induction loops (one- or both-sided), different roof types, lighting with or without twilight switch as well as foundation frames for installation on paved roads.

Technical data	MPG 162	MPG 172
Voltage	110 - 240 V AC	110 - 240 V AC
Frequency	50 / 60 Hz	50 / 60 Hz
Power consumption max.	50 W	50 W
Duty cycle	100 %	100 %
Drive unit	MHTM™	MHTM™
Opening / closing times	approx. 3 sec	approx. 3 sec
Passage width	1086 mm	1070 mm
Housing dimensions (WxLxH)	1451 x 533 x 2234 mm	1623 x 645 x 2234 mm
Weight	250 kg	320 kg
Temperature range	-25 bis +50 °C	-25 bis +50 °C
Protection class	IP 43	IP 43

Dimensions MPG 162

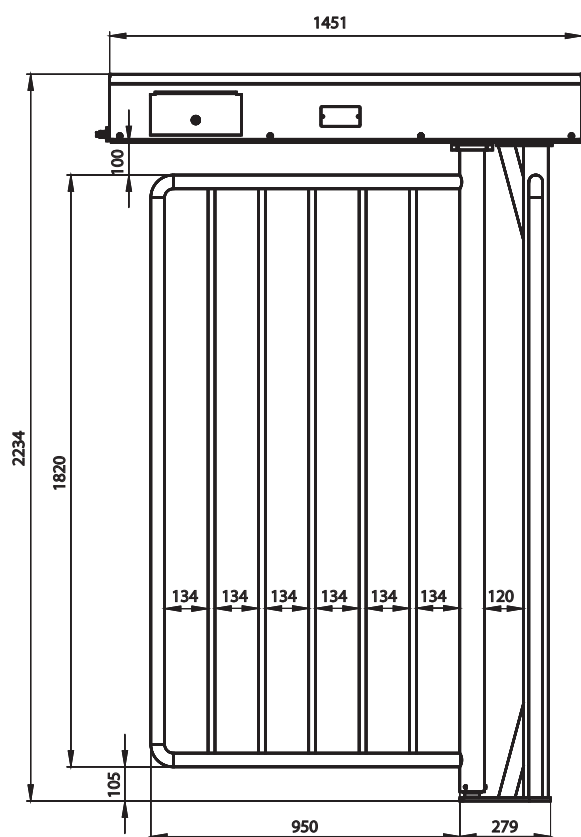

Dimensions MPG 172

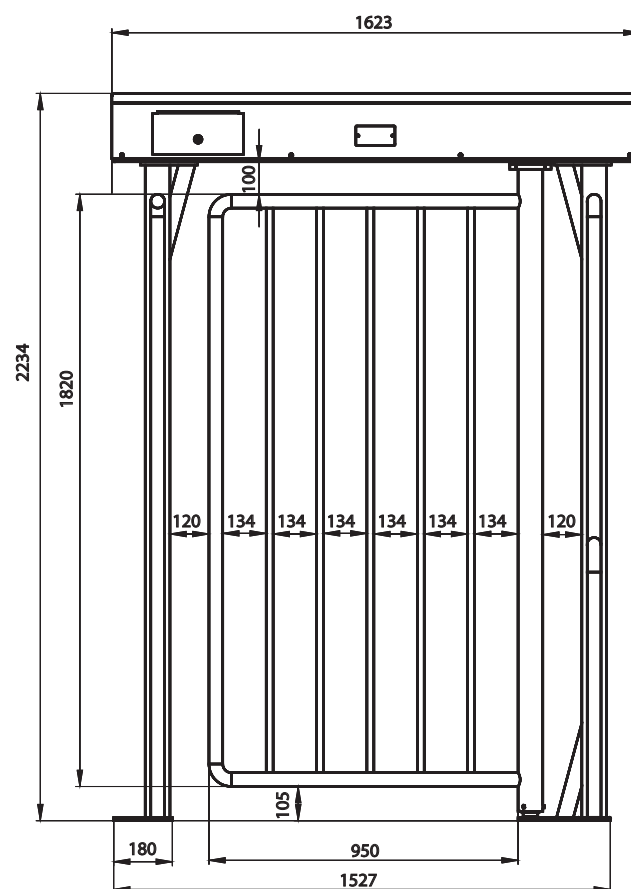

Pedestrian Gates

MPP 122 / 222

The MPP series is designed to control pedestrians entering or exiting restricted areas, usually under surveillance, in low security situations. Personal surveillance is therefore recommended as the barrier can be breached.

The barrier consists of a rotating center, at 3 x 120 degrees, providing single access via a card reader or external control panel through steps of 1 x 120 degrees. The operation of the barrier allows for controlled bidirectional pedestrian flow and is capable of blocking in either direction, or free rotation in either direction.

This model can be used in two directional control applications with a high usage of pedestrian traffic such as: railway platforms, passenger terminals and sport stadiums.



Housing and quality

The construction consists of a center housing connected to two end modules. The center housing has a dust / waterproof hinged locked cover providing maximum access to the controllers and electro-mechanical drive mechanism. Various optional access control devices (such as card readers, finger print readers etc) can be accommodated on a fascia panel at the ends of each gate. There are two versions available for indoor (MPP 122) and outdoor applications (MPP 222).

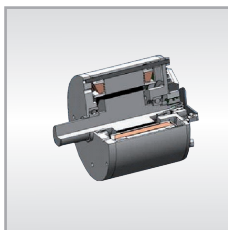

Motor and control unit

The MHTM™ motor with sensor technique offers almost silent operation. The motor allows a direct drive of the rotating center without additional gearing. It operates under constant power and thus prevents condensation and prolongs the life of the motor. In connection with the universal MBC controller we can provide features that are very useful and expedient for our customers.



Drop-Arm mechanism

In case of an emergency or power failure, any pedestrian gate must not be an obstacle. The optional available patented drop-arm mechanism releases the arms of the tripod so that the gate can be safely passed. Afterwards, the arms return to their correct position and the rotating center resets and returns to the home position.



Typical Fields of Application

Magnetic pedestrian gates are designed for a huge number of applications. The MPP series may be used for train stations, airports, sport stadiums, museums, company entries, public baths, public convenience.

Technical data

MPP 122 / 222

Voltage	110 - 240 V AC
Frequency	50 - 60 Hz
Power consumption max. ¹	65 W
Duty cycle	100 %
Drive unit	MHTM™
Protection class	IP 32/44
Housing dimensions (WxLxH)	260 x 1300 x 1035 mm
Weight	60 kg
Temperature range	-25 to +50 °C

¹ during movement, without optionally available heating

Dimensional drawings

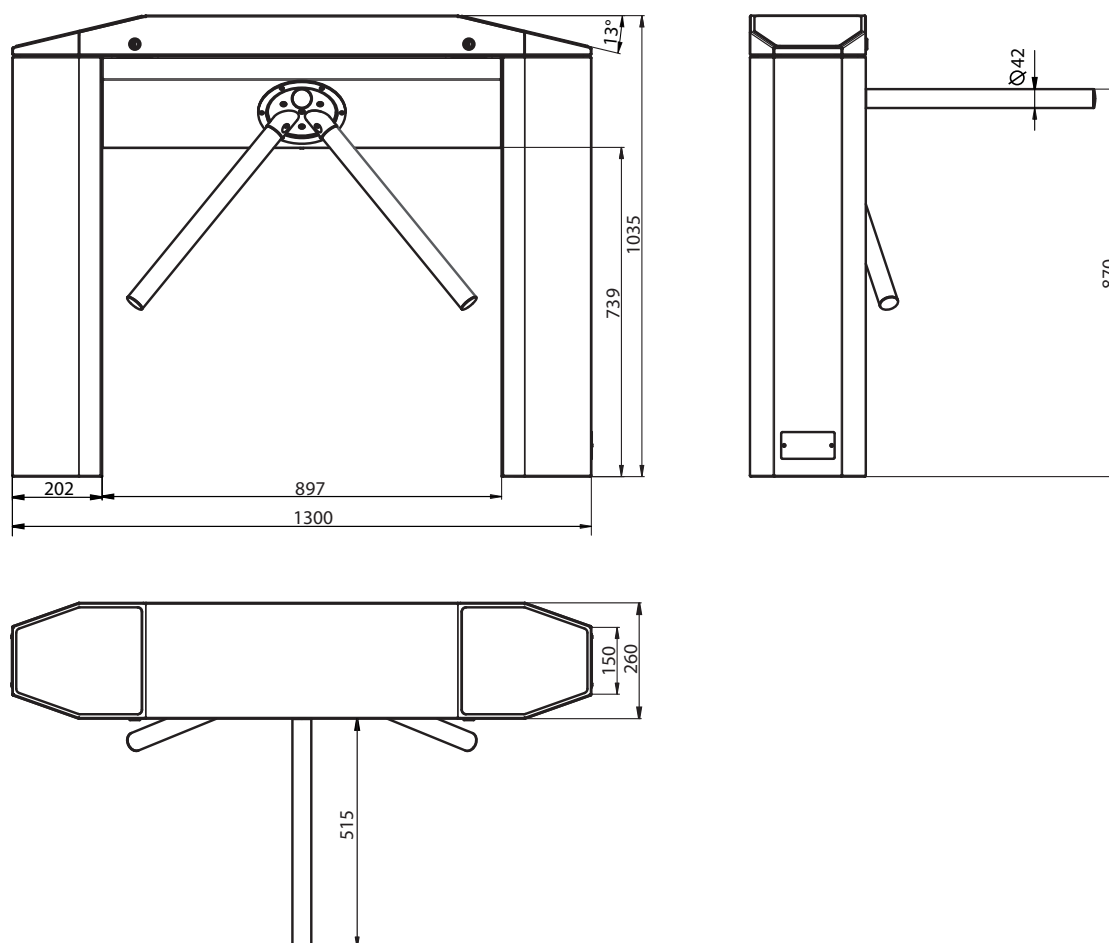

Pedestrian Gates

MPR 112

The MPR series is designed to control pedestrians entering or exiting restricted areas, usually under surveillance, in low security situations. Personal surveillance is therefore recommended as the barrier can be breached.

The aisle is blocked by means of a retractable triangular wing made of an aluminum core construction covered by PU-foam. Alternatively an acrylic glass wing is available. Two different models allow two different passage widths (520mm and 960 - 990mm).

The MPR series can be used in bidirectional applications to control the entry and exit with only one line. A line or installation consists of at least two modules.



Housing and quality

The housing made of stainless steel is separated into three segments. The locked middle segment contains the controller and the drive unit. Access control devices (such as card readers, finger print readers etc.) can be installed on a stainless steel fascia panel located at each end segment. These segments also contain the Gate End Displays showing the current operational state to the user. The housing offers protection class IP 32.

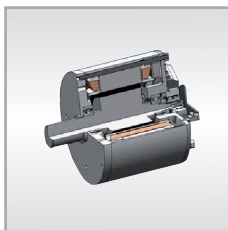

Motor and control unit

The MHTM™ motor with sensor technique offers almost silent operation. The motor allows a direct drive of the rotating center without additional gearing. It operates under constant power and thus prevents condensation and prolongs the life of the motor. In connection with the universal MBC controller we can provide features that are very useful and expedient for our customers.

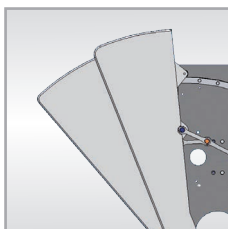

Wing types

The standard wing for the MPR series is made of an aluminium core construction covered with PU-foam. This patented pending construction allows to block even an passage of 960 to 990 mm with the slim housing width of 280 mm. Furthermore, a significant increase of the opening und closing time can be achieved, resulting in a much better tailgating behavior.

Alternatively, acrylic wings may be used (for passage widths of 520mm only).



Safety

Persons passing the gate are monitored by eight photocells. They detect the direction and prevent closure as long as a person or object is within the safety zone. The gate closes automatically when the lane is cleared. Unauthorised attempts at access/passage are detected and can trigger an alarm signal. In the event of a power failure or in an emergency the gate opens to provide free passage.

Technical data	MPR 112 (250)	MPR 112 (280)
Voltage	110 - 240 V AC	110 - 240 V AC
Frequency	50 - 60 Hz	50 - 60 Hz
Power consumption max.	35 W	117 W
Duty cycle	100%	100%
Passage width	520 mm	960 - 990 mm *
Housing dimensions (WxLxH)	250 x 1300 x 1035 mm	280 x 1300 x 1035 mm
Drive unit	MHTM™	MHTM™
Opening / closing times (acryl wing)	0.35 s	-
Opening / closing times (soft wing)	0.3 s	0.6 s
Protection class	IP 32	IP 32
Temperature range	0 to +45 °C	0 to +45 °C

* For a passage width of 960mm, the gap between the open wings is 50mm. For a passage width of 990mm, the gap is 80mm.

Dimensional drawings MPR112 (250) / Passage width 520 mm

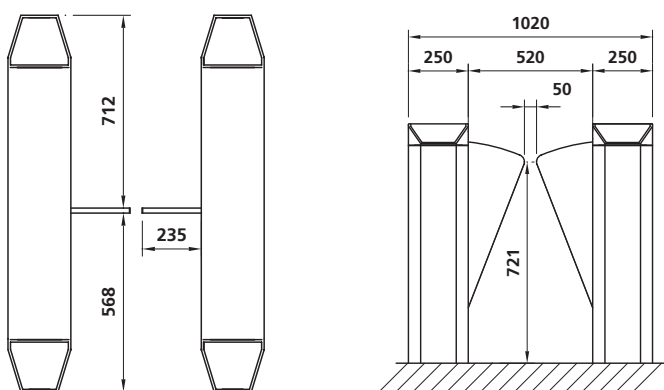

Dimensional drawings MPR112 (280) / Passage width 960-990 mm

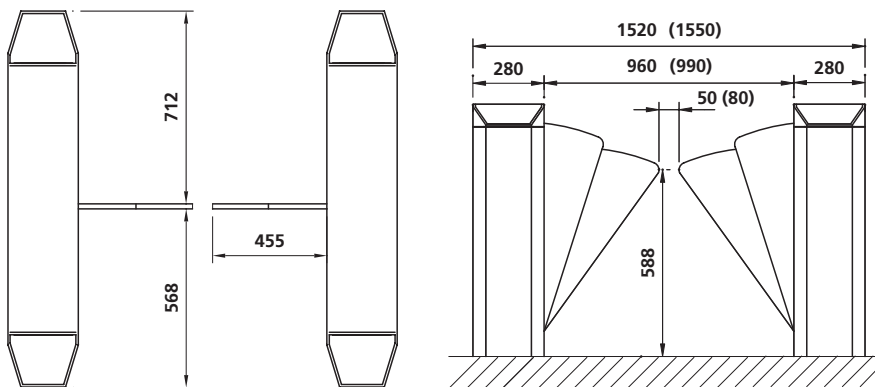

Pedestrian Gates

MPS 122

The MPS series is designed to control pedestrian access in basic security applications with surveillance. It may also be used as supplement to other Magnetic pedestrian gates, in particular to provide passage for wheelchairs and for persons carrying large items.

The MPS pedestrian gate consists of a tube with two or three brackets for mounting barrier elements. These can be standard elements (see picture), glass or customer-specific elements.

The MPS series can be used in bidirectional applications to control the entry and exit with only one gate.

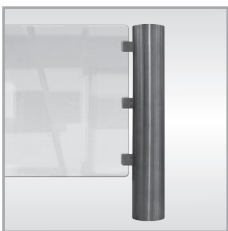
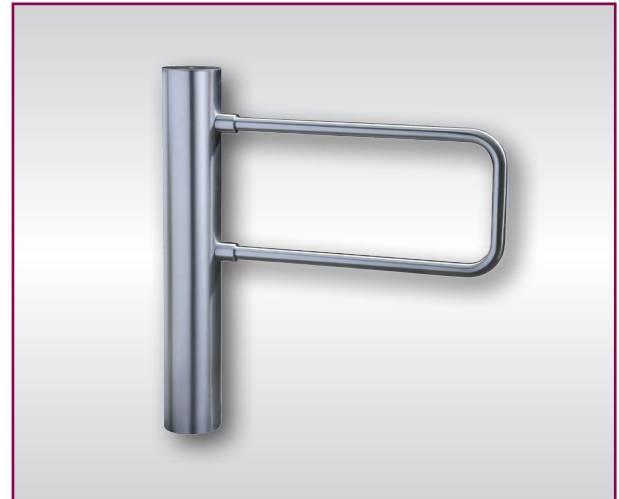

Housing and quality

The housing (column) is basically a polished, grade 1.4301 (V2A) stainless steel tube with a diameter of 159 mm, which provides degree of protection IP 44. The drive unit is concealed within the housing and rotates the outer stainless steel tube. This rotatable part of the gate has two or three brackets for mounting barrier elements. These can be standard rails, glass flaps (toughened safety glass or laminated glass), or customer-specific barrier elements.

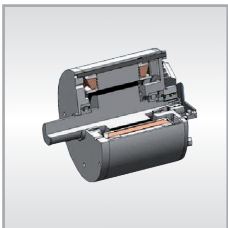

Motor and control unit

The key component of the MPS drive is the highly dynamic MHTM™ motor with precision position feedback. The major feature of this motor is its high torque combined with harmonic opening and closing motions. This ensures fast acceleration and braking, and, at the same time, low forces and improved safety. The MBC-110 logic controller offers adjustable speeds and opening times. The opening angle is adjustable over a wide range from 10° to 300°.

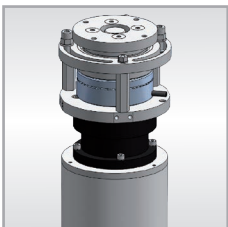

Locking / vandalism protection

An electromagnetic dog clutch allows the barrier to be locked in small steps; the positions are determined by the toothed clutch. This prevents the barrier from being forced out of its end position or moved against the released direction of passage. In the event of panic or vandalism, protection and safety are ensured by a force limiter. In the event of a power failure or in an emergency, the dog clutch opens to provide free passage.



Safety

The intelligent drive system recognises persons or objects in the swept zone during opening / closing. The behaviour of the barrier after contact with an obstacle is adjustable.

MPS swing gates are available in a version with approval for use in emergency exits and rescue routes.

Technical data
MPS 122

Drive unit	MHTM™
Voltage	110 - 240 V AC
Frequency	50-60 Hz
Power consumption	45 W
Opening / closing time	1.5 - 4.0 ¹
Opening angle	10 - 300°
Height	1000 mm
Diameter	159 mm
Weight	40 kg
Protection class	IP 44
Temperature range	-25 to +45° C ²

¹ Depending on dimensions, for 90° movements

² With heating activated

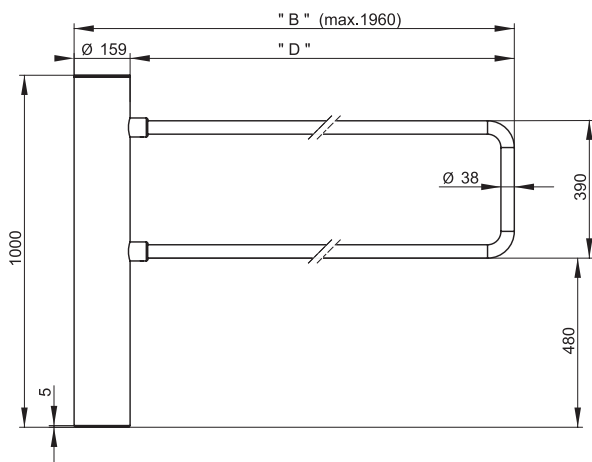
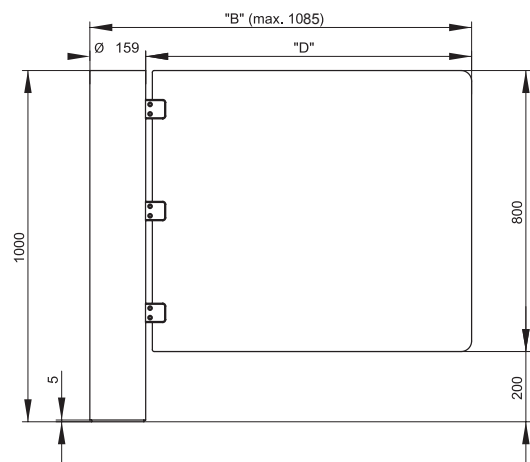
Dimensional drawing with U-shaped rail

Dimensional drawing with glass flap

Pedestrian Gates

MPH 112

The MPH (Magnetic Pedestrian High Door) Series pedestrian barrier was developed to control the access of persons under medium to high security requirements.

Closure takes place immediately after passage or after an adjustable hold-open time. The opening and closing times can be programmed to be different from each other, the times depend on the height of the glass flaps. In its initial position the barrier is closed; it can be operated in one direction only, or in both directions.

MPH barriers are available in two versions. The standard version permits unimpeded passage for persons. The Wide lane has a greater lane width and provides optimum passage for persons with luggage and for wheel chairs.

A line or installation consists of at least two modules.



Housing and quality

The housing is made of stainless steel grade 304 (1.4301) and is built up from several segments whose length can be varied to suit the customers requirements. Various optional access-control systems (e.g. card readers) can be readily integrated into the stainless steel front panels. The housing complies with degree of protection IP32 and is suitable for indoor applications, or for outdoor use under a roof (but only with additional heating).

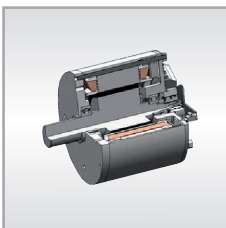

Motor and control units

The MHTM™ motor with sensor technique offers almost silent operation. The motor allows a direct drive of the rotating center without additional gearing. It operates under constant power and thus prevents condensation and prolongs the life of the motor. In connection with the universal MBC controller we can provide features that are very useful and expedient for our customers.

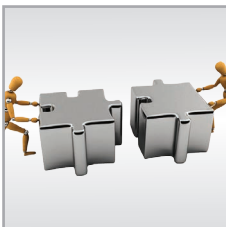

Customization

MPH112 gates are available with three different door heights depending on the security standard demanded by the customer. Magnetic recommends 1200 mm doors for medium security requirements. For high security, we recommend 1500 mm or 1800 mm doors to make climbing over them more difficult.

The glass doors are made from toughened or laminated safety glass.



Safety

Persons passing the barrier are monitored by eight photocells. They detect the direction and prevent closure as long as a person or object is within the safety zone. The barrier closes automatically when the lane is cleared. Unauthorised attempts at access/passage are detected and can trigger an alarm signal. In the event of a power failure or in an emergency the barrier opens to provide free passage.

Technical data	MPH 112 (Standard lane)	MPH 112 (Wide lane)
Voltage	110 - 240 V AC	110 - 240 V AC
Frequency	50 - 60 Hz	50 - 60 Hz
Duty cycle	100 %	100 %
Drive unit	MHTM™	MHTM™
Passage width	520 mm	910 mm
Housing dimensions (WxL)	300 x 1300 mm	520 x 1300 x mm
Door heights	1200 / 1500 / 1800 mm	1200 / 1500 / 1800 mm
Power consumption max.	100 W	300 W
Opening / closing times	0.6 - 1.2 s	1.0 - 1.4 s
Protection class	IP 32	IP 32
Operating temperature	0 to +45 °C	0 to +45 °C
Weight for one lane	approx. 200 kg	approx. 275 kg

Dimensional drawings MPH112 (Standard Lane)

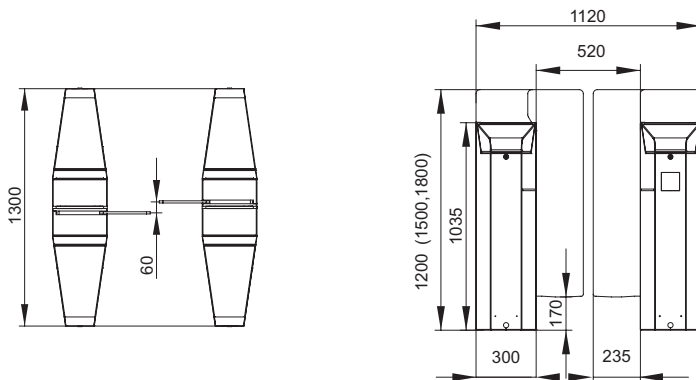

Dimensional drawings MPH112 (Wide Lane)

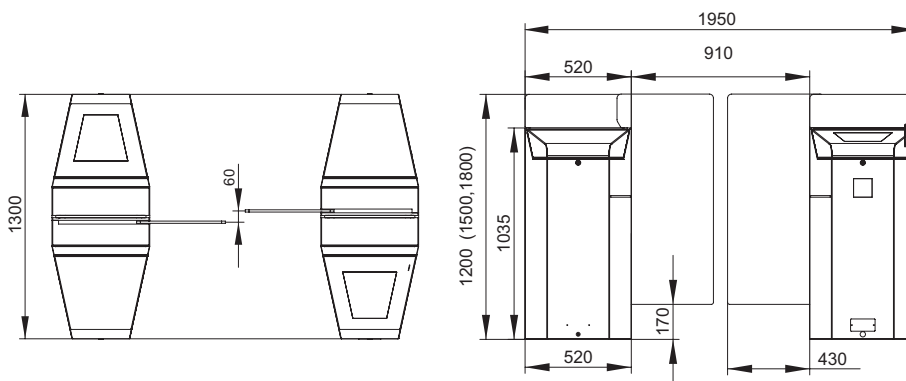

Pedestrian Gates

MPW 112

The Magnetic Pedestrian Wing (MPW) series is designed to control pedestrians entering or exiting restricted areas in medium to high security applications.

The gate closes immediately after passage or after an adjustable time-out. The opening and closing time of the gate can be programmed differently depending on the size of the objects. The gates can be operated in one-way or bidirectional mode.

The key component of the MPW series is the direct drive system with the MHTM™ motor. No additional gear-box is required. It offers numerous benefits including nearly noise-free operation, small dynamic forces, impact detection, almost no abrasion and fastest opening / closing times.

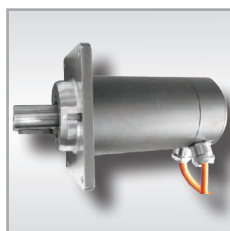
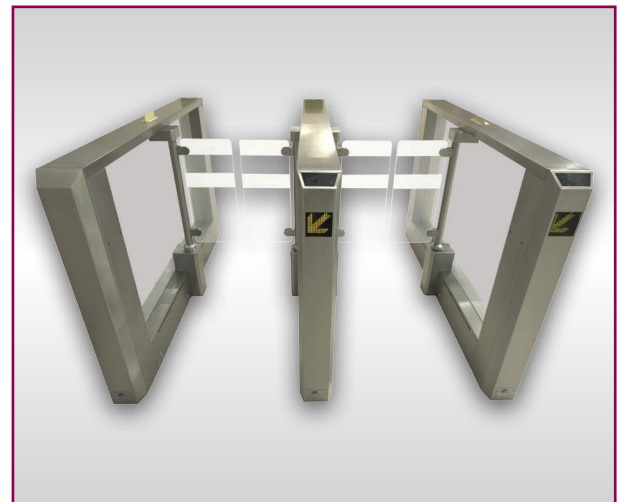

Motor technology

The MHTM™ drive system consists of resolver for precise positioning feedback. It is a motor with high output torque for fast acceleration and fast deceleration which is one of the main features of the motor. When there is no power, the motor shaft can be freely rotated. The MHTM™ lifetime is more than 10 million cycles or a minimum of 10 years in a pedestrian gate application.



Logic controller

The logic controller provides a high level of flexibility. It is able to control gate operation either by commands received from one of the serial communication ports or by digital inputs and outputs. The logic controller is in full control of processing a passage through the gate when opening commands are received from external access control devices such as card readers, fingerprint readers, ticketing devices, etc.



Fraud and Safety

Passengers travelling inside the gate are observed by PE beams. They detect and prevent attempts to defraud such as intrusion, wrong-way and tailgating. In combination with the low impact forces, the PE beams provide a high safety level. To prevent any attempts to force the doors open, they are blocked by electromagnetic tooth-brakes in the closed position. In case of power failure or an emergency the wing doors are pulled open by springs.



Gate End Display

The Gate End Display is used to indicate independently for each direction whether a lane is opened or closed. Two symbols can be displayed: green arrow and red cross.

Technical data
MPW 112

Voltage	110 - 240 V AC
Frequency	50 - 60 Hz
Power consumption (typical)	120W
Opening / closing times	0.6 s
Duty cycle	100 %
Housing dimensions (WxLxH)	150 x 1750 x 1045 mm
Passage width	550 mm (MPW 112) / 900 mm (MPW 112W)
Wing material	Clear Polycarbonate / glass
Ambient temperature	-25°C to 45°C
Protection class	IP 32

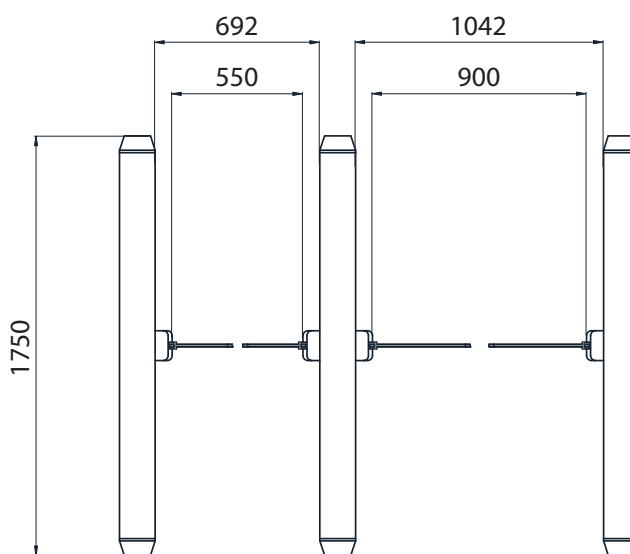
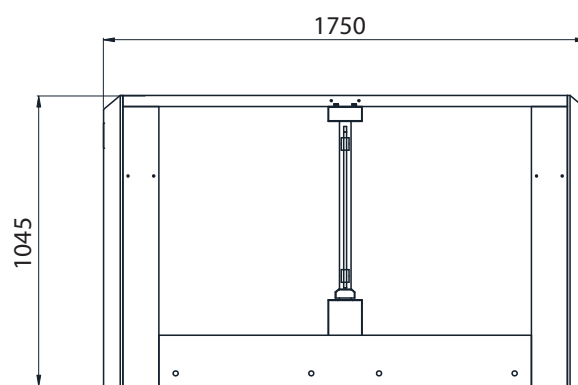
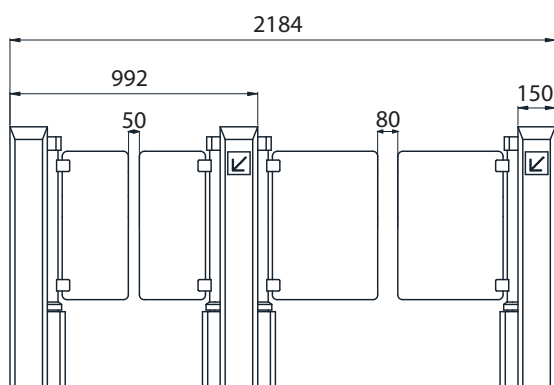
Dimensional drawings

Pedestrian Gates

MOB 112

The MOB series is designed to control pedestrians entering or exiting restricted areas in low security situations - usually under surveillance. Personal surveillance is recommended as the barrier can be breached.

Compared to traditional pedestrian gates, the MOB series is based on photocells to recognize and control pedestrians entering or leaving a secured area. Neither a motor / drive unit nor moving mechanical parts are needed resulting in minimized servicing and maintenance costs. Thus, MOB gates provide a cost-effective alternative.

MOB pedestrian gates allow for bidirectional pedestrian flow and detection of tailgating, wrong way usage and crawling.

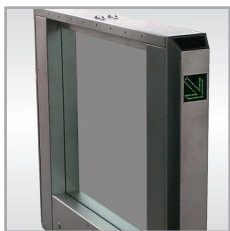
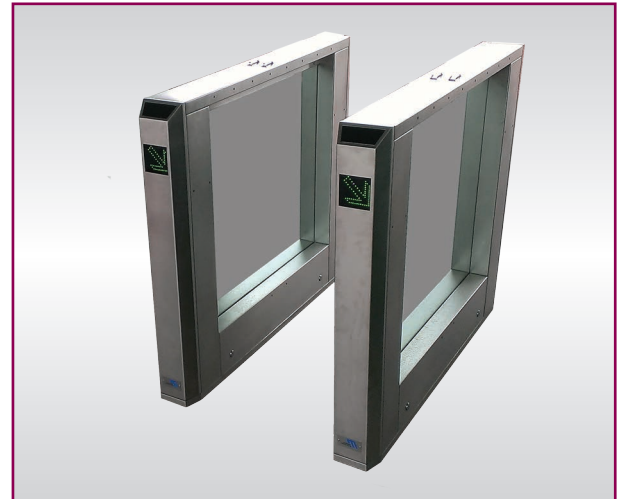

Housing and quality

The housing made of stainless steel (optionally available: powder-coating) offers protection class IP 32. Access control devices (e.g. card readers, finger print readers etc.) can be installed or optionally integrated into the front segment. Two integrated LEDs indicate the validation of an access attempt: green light means access granted, red light means access denied, tailgating or wrong way.



Control unit

The system is supplied with the user-friendly Magnetic Barrier Control (MBC) with advanced logic control software. The control unit enables you to control the LEDs / GED displays as well as to configure timings and tailgate alarms to meet your requirements.



New Gate End Display

The Gate End Display is used to indicate independently for each direction whether a lane is opened or closed. Two symbols can be displayed: green arrow and red cross.



Typical fields of application

MOB gates are typically used for the control of pedestrian flow of offices, receptions and lobbies, factory and company entrances as well as government facilities.

Technical data

MOB 112

Voltage	110 - 240 V AC
Frequency	50 - 60 Hz
Passage width (recommended)	520 mm
Housing dimensions (WxLxH)	150 x 1300 x 1045 mm
Sensor technology	Photo Electric IR sensor, 8 pairs
Type of command signal and integration	Dry contact or RS232
Directional control	By dry contact or RS232
Protection class	IP 32
Temperature range	-30° to +45 °C

Dimensional drawings MOB 112

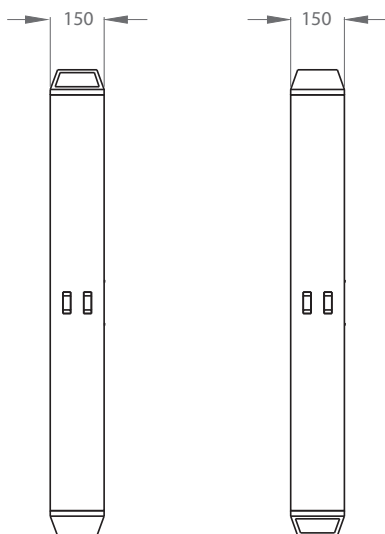
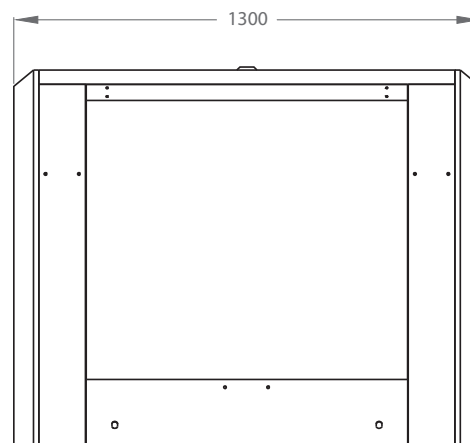
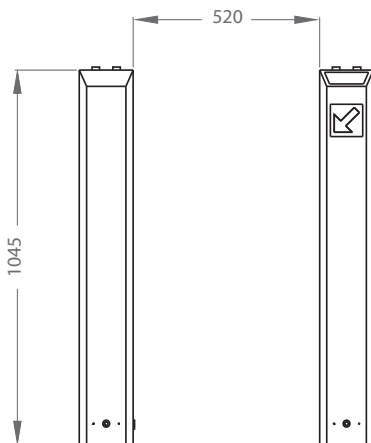

Power Door Products

(914) 698-5083

www.PowerDoorProducts.com